

JZ10100R-MP

Image Size: $\frac{2}{3}$ $\frac{1}{2}$ $\frac{1}{3}$

【SPECIFICATIONS】 2/3" Megapixel Motorized Zoom Lenses

Focal Length :	10~100mm	Operation :	Zoom :	Motorized(DC±6.4V, Max40mA) Speed Approx.6sec.
Maximum Relative Aperture :	1:1.4		Focus :	Motorized(DC±6.4V, Max40mA) Speed Approx.7sec.
Iris :	F1.4~Close		Iris :	Motorized(DC±6.4V, Max40mA) Speed Approx.3.5sec.
Zoom Ratio :	10X			
Angle of View :	47.5×36.5 deg. at 10mm 5.0× 3.8 deg. at 100mm	Operation Temperature :		-10~+50°C
Image Size :	8.8×6.6mm (φ11mm)	Mount :		C-Mount(Adjustable Lens Position)
Minimum Object Distance :	1.2m (From Front Vertex)	Filter Size :		62mm P0.75
Optical Back Focal Distance :	14.69mm (In Air)	Size :		80×70×122.3mm
Flange Back :	17.526mm	Weight :		Approx.700 g

【COMPOSITION】

- Lens 1
- Lens Cap 1
- Dust Cap 1

【DIMENSIONS】

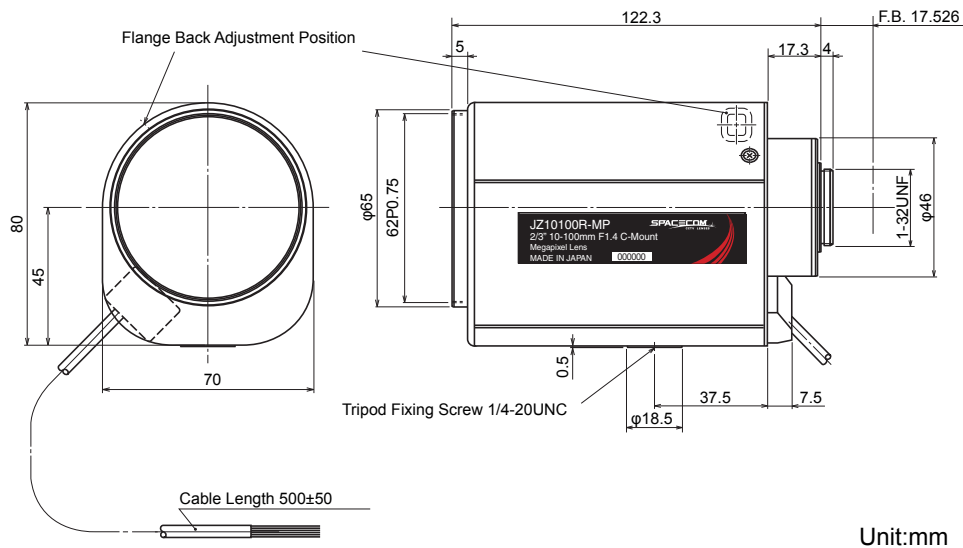

Unit:mm

【CIRCUIT DIAGRAM】

